

PRODUCT FEATURES & TECHNICAL INFORMATION

- A traditional projection weld on hinge made from mild steel
- Projection allows opening of 180 degrees clearing a reveal or mullion
- Friction washer once fitted, enables window to have friction resistance
- Requires a suitable finish to be applied, *these are normally fixed to the window during preparation stages*
- S1025NA is supplied with bolt & nut for fitting
- S1025BP is supplied with a brass pin for fitting. *This requires riveting during assembly and can be fitted in either direction to the hinge allowing for different aesthetic appearances*
- Hinges are supplied as a pair

S1025 Projection Corner Traditional Weld on Hinge



S1025NA



S1025BP

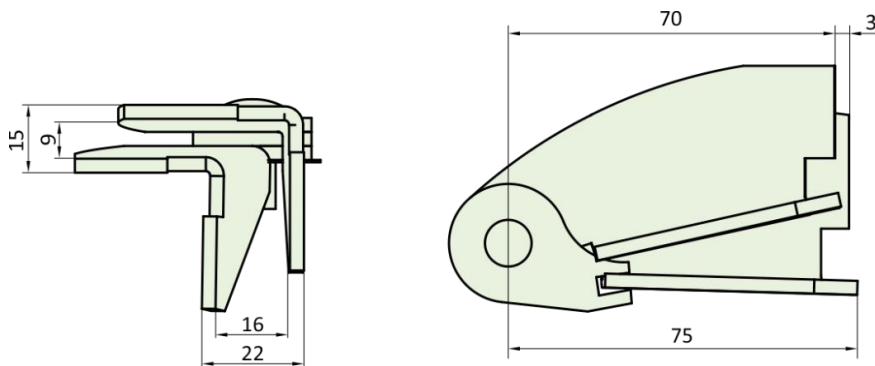

Dimensions